



The best refrigerant air dryers: durable, highly performant even in extreme working conditions, environmentally friendly thanks to the use of 134a refrigerant in all models.

Why is air cleansing necessary ?

In most manufacturing industries, compressed air represents an absolutely essential utility and process medium. To avoid unnecessary breakdown, compressed air must be dry, clean and oil-free. High humidity in compressed air pipes can damage the pipe itself **as well as all the components of the network** and will result in corrosion.

The TRISAB heat exchanger

The heart of the new DS series is the TRISAB heat exchanger, representing a totally innovative design concept. Its particularly wide and compact heat exchange surface guarantees a mode of operation unaffected by load and keeps the dew point stable. It is the use of very generously dimensioned flow ducts which makes the extremely low pressure differences possible. Thanks to the high reserves of load tolerance, these units are particularly suited for functioning in a variety of world climates.

The TRISAB heat exchanger

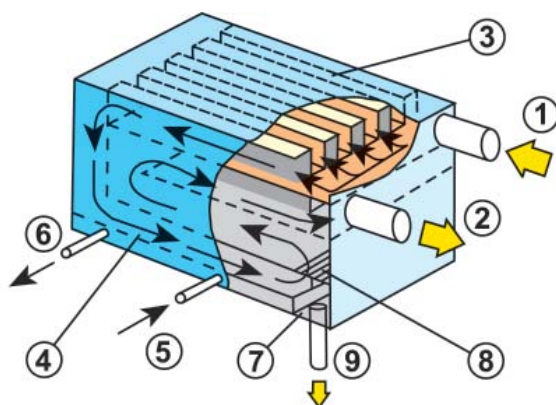

- 1 - Compressed air inlet
- 2 - Compressed air outlet
- 3 - Air-to-air heat exchanger
- 4 - Refrigerant-to-air heat exchanger

- 5 - Refrigerant inlet
- 6 - Refrigerant outlet
- 7 - Condensate trap
- 8 - Droplet separator
- 9 - Condensate discharge

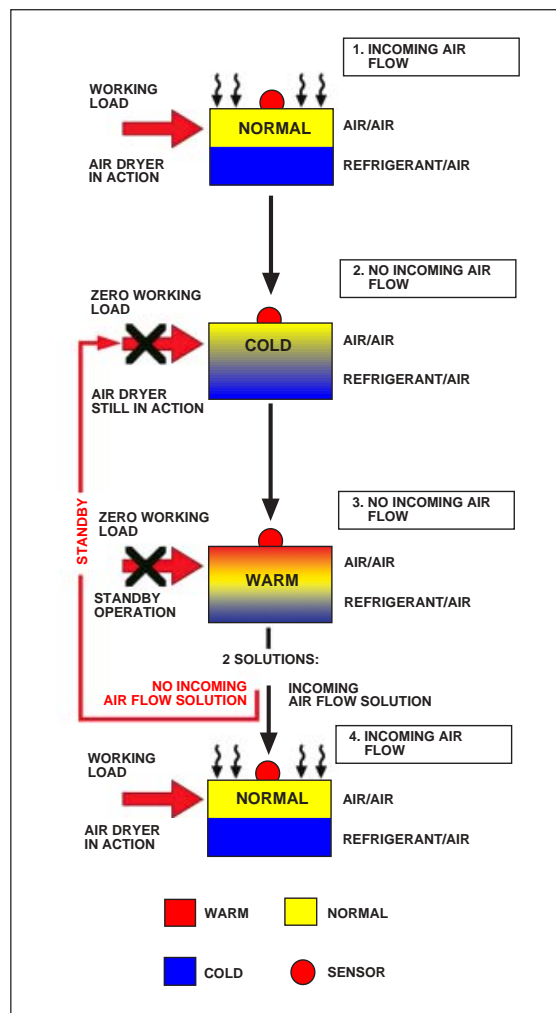

The standby operation

All current DS dryer models* are equipped with a new, innovative control system that uses microprocessor technology to obtain considerable energy savings. Thanks to the high precision of all the electrical components, the DS dryers automatically switch to the standby operation during longer periods of zero-load, using the TRISAB heat exchanger as a cold storage mass. This results in important energy savings, up to 90%, while maintaining a constant availability of the dryer. The TRISAB heat exchanger acts as a thermal mass and will provide effective compressed air capacity across a wide and fluctuating range of compressed air flow. All standby functions are shown in the graph above.

* With exception of the DS 0065 model, which is available upon request.

DS Series Air Dryers

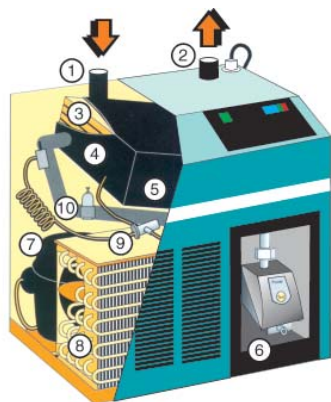

- 1 - Compressed-air inlet
- 2 - Compressed-air outlet
- 3 - Air-to-air heat exchanger
- 4 - Refrigerant-to-air exchanger
- 5 - Condensate separator

The high-efficiency DS air dryers, conceived for the 65-8750 m³/h range, deliver dry compressed air. Main features are: low pressure drop, excellent performance and low energy consumption.

The principal benefits of the DS series:

- Proven TRISAB heat exchange
- Energy savings up to 90% in the standby position
- Low refrigerant charge
- Use of a single refrigerant for all models in this series (R 134a)
- Compact layout
- A microprocessor system for the recording and storage of technical data (starting from DS 2750 model)

- 6 - Microprocessor controlled condensate drain
- 7 - Hermetically sealed refrigerant compressor
- 8 - Refrigerant condenser
- 9 - Thermostatic expansion valve
- 10 - Refrigerant controller

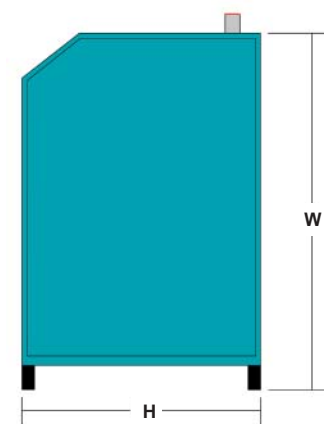

DS 0550 - DS 1500

Model	Capacity m ³ /h ¹⁾	Power supply V/50Hz	Power consumpt. kW	Suitable for	Air cooling flow m ³ /h	Air connect. R"/DN	Weight kg	Dimensions mm length x width x height
DS 0065	65	230	0,28	T10	450	3/4"	41	450 x 450 x 500
DS 0100	100	230	0,38	T20	450	1"	48	450 x 600 x 550
DS 0175	175	230	0,52	T30	770	1"	53	450 x 600 x 550
DS 0225	225	230	0,69	-	770	1½"	70	600 x 600 x 650
DS 0300	300	230	0,82	-	770	1½"	80	600 x 600 x 650
DS 0375	375	230	0,96	UR6	770	1½"	95	600 x 600 x 650
DS 0550	550	230	1,20	UR9	1300	2"	150	800 x 900 x 1200
DS 0750	750	230	1,40	UR12	2300	2"	166	800 x 900 x 1200
DS 0850	850	230	1,50	-	2100	2"	175	800 x 900 x 1200
DS 1175	1175	400	2,10	UF18	2100	2½"	180	800 x 900 x 1200
DS 1500	1500	400	2,70	UF26	1800	2½"	190	800 x 900 x 1200
DS 2750	2750	400	4,40	UF40	10000	DN100	460	1200 x 1200 x 1900
DS 3500	3500	400	5,70	-	9500	DN150	600	1200 x 1200 x 1900
DS 7000	7000	400	12,20	-	20000	DN200	1010	1200 x 2225 x 1900
DS 8750	8750	400	14,50	-	19000	DN200	1180	1200 x 2225 x 1900

Capacities according to **DIN ISO 7183** referred to :

working pressure : 7 bar
 air inlet temperature : +35 °C
 ambient temperature : +25 °C
 dew point : +3 °C
 pressure drop : from 0,1 to 0,3 bar
 max. ambient temperature : +50° C
 max working pressure : 16 bar

1) Capacity referred to 1 bar abs. and +20° C

Other capacity models available on request.

The performance of DS dryers is related to the working conditions of the machine.
 A considerable increase in capacity and/or air inlet temperature will reduce the performance of the machine.

Pneumofore SpA
 Headquarters
 Via N. Bruno, 34
 10090 - Rivoli - Italy

Tel: +39 011.950.40.30
 Fax: +39 011.950.40.40
 Email: info@pneumofore.com
 Web: www.pneumofore.com

Pneumofore  
 ISO 9001
 CERTIFIED

Since 1923 Air Compressors and Vacuum Pumps
 Plant Engineering Worldwide Service

Pneumofore strives to constantly improve its products and reserves the right to modify technical data with no prior notification. Contents of this documents are for informational purposes only and do not constitute a guarantee extension of any kind. Trademark and logo Pneumofore fi are registered worldwide. Copyright © Pneumofore SpA All rights reserved. Any unauthorized reproduction or dissemination of this document is strictly prohibited.