

Q Type Air Tanks



Since 1923, Pneumofore has been producing air compressors and vacuum pumps, featuring original solutions, the result of constant efforts in research and development.

Air tanks are indispensable accessories for compressed air plants. They allow instantaneous air delivery that may even exceed the compressor capacity and set to a minimum the drops in network pressure.

Choosing an air tank

The air tank is chosen in accordance to the effective capacity of the compressor to be installed: for low capacities, the air tanks usually have 2/3 volume capacity.

Auxiliary air tanks of smaller volume should be installed where the air requirement are more variable and/or instantaneous, in order to control sudden and unpredictable changes of pressure.

The table below shows the air tank's capacity in relation to required compressor models.

Type	T10	T20	T30	UR6	UR9	UR12	UR18	UR26	UR40
Air flow m ³ /h	68	102	168	355	550	755	1110	1525	2545
Capacity m ³	1	1	2	4	6	6	10	20	20

Features

Air tanks are tested by the Italian safety regulation body ISPESL and compliant with EC regulations.

Up through Q4000, all air tanks are tested for 12 bar operating pressure, while higher capacity models are tested for 8 bar operating pressure.

All tanks are supplied with safety valve, pressure gauge and drain pipe for condensate water.



Condensate discharger



Pressure gauge



Safety valve

Pneumofore supplies air tanks with superior capacity according to any given specification, and also special air tanks for vacuum plants (QV series).

Pneumofore also provides a full range of additional accessories and supplies for any plant, including dryers, filters, control systems, and special lubricants.

Benefits

Correctly sized air tanks offer the following benefits:

- **electric energy saving** thanks to the use of lower power compressors and to less load/unload cycles of the machine per unit time.
- **better compressed air purification.**
- **network pressure stability.**
- **precious energy reserve** in case of power outage.
- chance to evaluate with good approximation the compressors capacity, the air consumption and losses in the supply network - in other words, the overall plant efficiency.

Installation

Air tanks can be installed indoors or outdoors depending on the climate. In mild climates, it is better to place them outdoors, for space economy and to utilize the natural cooling for compressed air during winter and intermediate seasons. The possibility of condensate water collection in air tanks improves the compressed air quality without any additional costs. In processes where it's useful to employ hot compressed air, like in pressing and forging plants, it's better to insulate the tanks and the distribution heads.

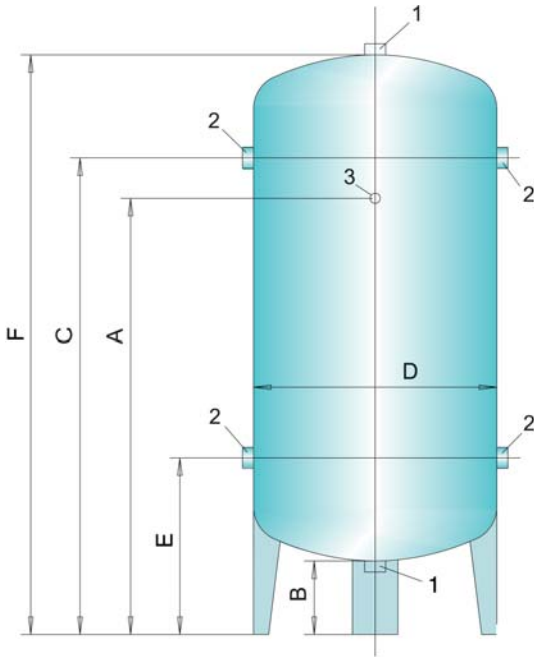

Capacity m ³	A	B	C	D	E	F	1	2	3
0,3	1455	180	-	500	585	1820	2"	1"	3/8"
0,5	1550	185	-	600	770	2040	2"	1"	3/8"
0,72	1580	155	-	750	870	2000	2"	1"	3/8"
1	1820	230	-	800	770	2430	1 1/4"	2"	3/8"
2	1900	220	2080	1100	770	2450	1 1/4"	2 1/2"	1/2"
3	1835	320	2600	1200	1000	3240	1 1/4"	2 1/2"	1/2"
4	1835	320	3340	1200	1000	4180	1 1/4"	2 1/2"	1/2"
5	1835	320	2470	1600	1060	3250	1 1/4"	4"	1/2"
10	-	-	-	1600	1060	5740	1 1/4"	4"	1/2"



Determination of Air Delivery

The compressor capacity can be determined with sufficient precision by calculating the time spent in raising the pressure of 1 bar whereby the output valve is closed.

$$\dot{V} = \frac{V \cdot \Delta p \cdot 3'600}{t}$$

\dot{V} = compressor capacity [m³/h]
 V = tank capacity [m³]
 Δp = pressure difference [bar]
 t = time [sec.]

The same test executed with compressors turned off and working instruments, allows to calculate the air consumption's value plus the supply network losses.

Air tanks of higher capacity mean pressure stability, better decantation of condensate and impurities employing lower capacity compressors.

Industrial plants use vertical air tanks because of their smaller footprints; the vertical drop between input and output fittings enhances decantation and collection condensation, which is automatically discharged by our electronically controlled condensate drain UFM.T without air losses.

Pneumofore service offers advice for complete plant configuration without charge, and after-sales service is available for compressed and vacuum plant installation.

Installation Diagram

