

THE SHAPE OF VACUUM

# UV SERIES ROTARY VANE VACUUM PUMPS

## Vacuum solutions for industrial applications

Vacuum is the energy that Pneumofore delivers to its worldwide customers, ensuring **efficiency, reliability and accuracy in many industrial sectors**. With about 100 years of experience in different applications and in more than 50 countries, Pneumofore guarantees a unique know-how: every vacuum system project is considered according to the specific production needs, manufacturing environment and industrial process. That is why the **UV Series of rotary vane vacuum pumps is the best solution for energy savings, reduced operation costs and versatility even in the harshest environmental conditions**. Along with constant performance, Pneumofore units set another record: **the lowest Life Cycle Cost** in today's market.

### TECHNOLOGY

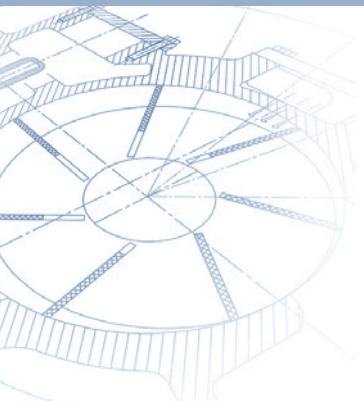

## performance and constant efficiency over time

Since its founding in 1923, Pneumofore has continuously developed and improved rotary vane technology. In the UV Series vacuum pumps, the concept of efficiency itself reaches new heights: the sliding vanes' active sealing ensures a **minimum residual pressure of 0,5 mbar(a)** while the high capacity delivered by the UV pumps allows **centralized vacuum systems**. These consists of few **high-performance units, that are easy to install and maintain**. The UV Series guarantees the highest performance compared to other single-stage machines, constant in every working and weather condition.

The UV Series **capacity ranges from 250 to 6.480 m<sup>3</sup>/h** single stage, with a nearly constant flow rate from 450 to 50 mbar(a). **The multi-stage option reaches an even higher flow** with vacuum values down to 0,05 mbar(a). UV Series pumps offer the highest flow rates and the lowest power consumption in the global market for single-stage rotary vane vacuum pumps.

### PRODUCTS

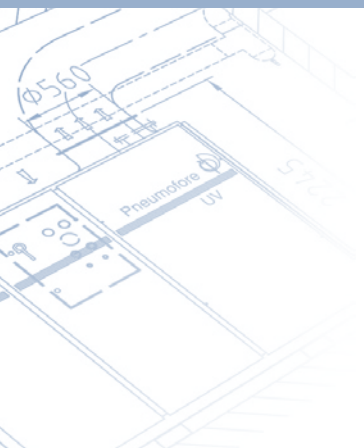

## tailored solutions and engineering

**What Pneumofore means by "customer care" is system design to worldwide assistance**. The UV Series vacuum pumps are **"ready-to-use"** machines, designed for easy installation and trouble free integration into the industrial process: an attentive care for the customer's needs that turns into high savings and the guarantee of reliability.

For every project, **Pneumofore designs a complete system that fits the specific application requirements**, delivering the best pumps and accessories sizing solution for the vacuum system centralization. Along with the standard version, the offer includes **special and customizable machines**: the VS version, with frequency converter for power consumption optimization and constant pressure, and the H version, for water vapor suction, are just few of numerous options.

**Pneumofore also takes care of its customers during the system start-up**, providing the appropriate maintenance training to the plant technicians. Furthermore, the **international service** ensures the ordinary and long-term maintenance at lower cost. Ultimately, the UV Series vacuum pumps can be supplied with **warranty as long as 5 years**.

### ENVIRONMENT



## sustainability and energy savings

The design efficiency and the mechanical parts durability guarantee **low power consumption** and provide added value in terms of **sustainability and reduced operating costs**. These are not promises but facts based on objective data.

**The air-cooling system of the UV Series vacuum pumps drastically cuts down the installation costs and resets to zero the expenses related to water connections, water treatment and disposal**. This means high savings and environmental protection, as water is the world's most precious resource. **The closed-loop lubrication circuit ensures negligible coolant consumption**, prevents air and environment contamination with harmful substances, and reduces maintenance requirements. The plant sizing, designed to fit the process needs, and the frequency converter option **considerably reduce the energy waste**, with increased savings and environmental sustainability. The simple, sturdy design and the use of built-to-last components also guarantee **low operational and maintenance costs**. Therefore, the UV series vacuum pumps offer the best Return on Investment when replacing other pumps and **the lowest Life Cycle Cost** in the market.

# APPLICATIONS



GLASS FORMING

ALUMINIUM CANS

DRYING AND DEGASSING

FOOD PROCESSING

PICK & PLACE

PASTA PRODUCTION

FOOD PACKAGING

METAL AND PLASTIC CONTAINERS FORMING

PHARMACEUTICAL INDUSTRY

VAPOUR RECOVERY

PIPELINE DRYING

CERAMICS, BRICKS AND TILES

AEROSPACE

ELECTRONICS

BOTTLING

SURFACE COATING

THERMOFORMING

EPS . . . . . and more

The UV Series vacuum pumps are operating in a variety of industrial processes where they can handle massive workloads at constant speed, 24/7, ensuring high reliability even in harsh environments with ambient temperatures up to 50°C. Along the standard version, the UV Series includes **special and dedicated machines**:

**UV VS Series\_** with **frequency converter** to lower the power consumption and to ensure constant pressure during the process

**UV H Series\_** for **water vapor suction**, with machine temperature at 110°C, specially designed **for drying processes**

**UV HC Series\_** air-cooled vacuum pumps for **hot climates** with ambient temperatures **up to 50°C**. They are equipped with oversized cooling system along with motor and fan for tropical climates

**UV HR Series\_** equipped with a combined air/water cooling system that allows the **heat recovery** for heating purposes

**UV B Series\_** **double-stage** vacuum system with a **roots booster** as second stage. It can be combined with every UV Series vacuum unit

**UV W Series\_** **water cooled** version for installation in closed areas

**UV IC Series\_** **inlet control** for evacuation starting from ambient pressure

**UV S Series\_** **special versions** with customized sizes, ethernet, stainless steel, off-shore paint and other special designs



UV100 VS220 HC



UV16 H IC B2500

# PARTS AND ACCESSORIES

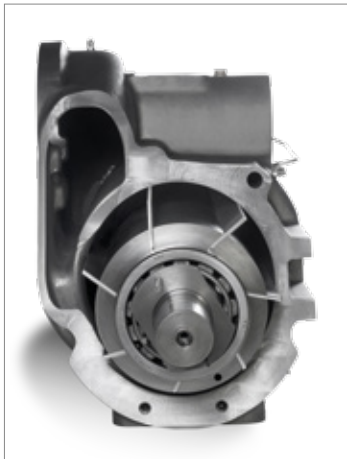

Air End section

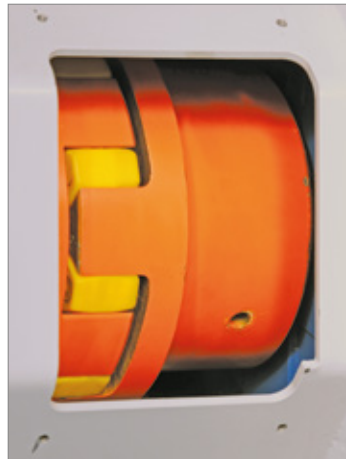

Direct Coupling

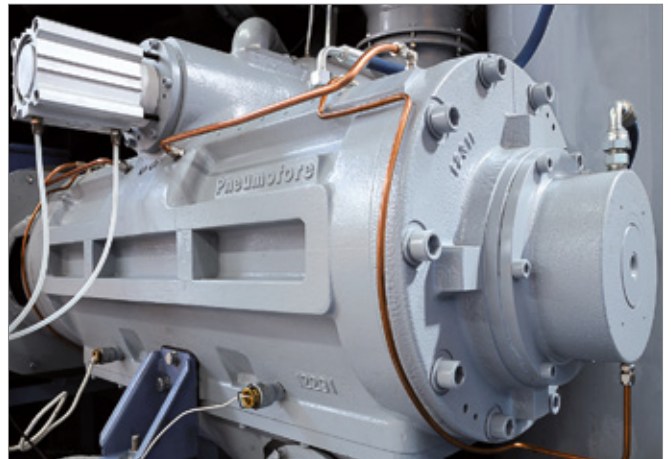

UV50 Air End

## UV SERIES VACUUM PUMP COMPONENTS

1. Air End
2. Coolant receiver and separator
3. Soundproof cabin
4. Cooling inlet air filter
5. Fan
6. Coolant radiator
7. Electric motor
8. Control and power panel
9. Air intake filter

- A. Air intake
- B. Exhaust
- C. Cooling air inlet
- D. Cooling air outlet

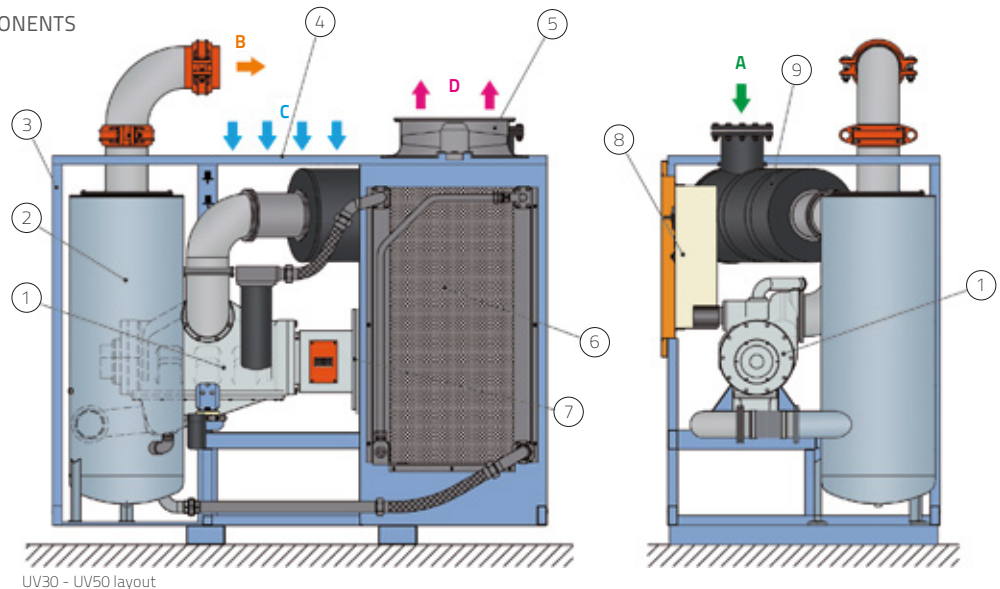

## UV SERIES SCHEMATIC OPERATING DIAGRAM

- Air / Coolant
- Air circuit
- Coolant circuit

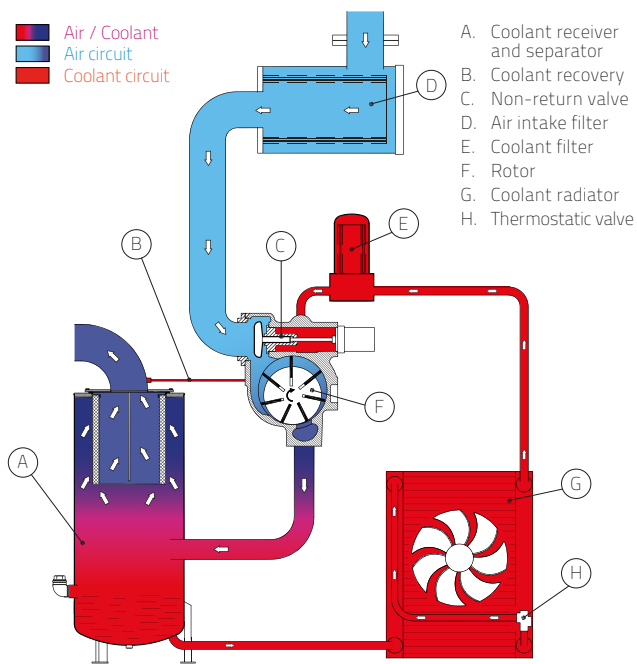

## VACUUM FLOW DIAGRAM at 50 Hz

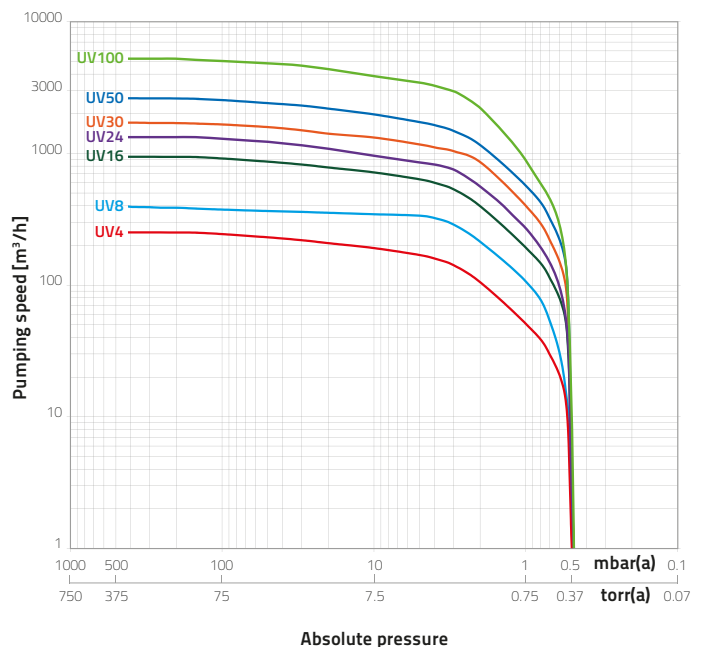

# UV SERIES Vacuum, signed by Pneumofore

The UV Series rotary vane vacuum pumps are easy-to-install, automatic units. They represent the best solution for the industrial vacuum production and for fast Return on Investment when replacing other pumps. The UV Series offers single-stage intake volumes of 250 up to 6.480 m<sup>3</sup>/h and 99,95% maximum vacuum degree reached with 0,5 mbar(a) residual pressure and constant performance curves: the best results for single-stage vacuum pumps. The high degree of vacuum and the constant efficiency guarantee superior performances along with significant energy and maintenance cost savings.



UV50 and UV16 open view

## MAIN FEATURES

**Air cooling system** through an aluminum radiator and electric fan thermostat for operating without cooling water

**No coolant consumption** thanks to the closed-loop lubrication circuit and high efficiency separation element

**Durability and efficiency** guarantee by the special aluminum alloy vanes that ensure constant performances even after decades of operation

**Reduced energy consumption** that other vacuum technologies cannot achieve

**Ready-to-use machines** that can be easily and directly connected to the vacuum plant and the power supply, with no need of foundations

**Limited footprint** thanks to the compact layout designed to minimize the space needs

**Direct coupling** between motor and air end to avoid energy losses

**Sound-proof cabin** for reduced noise impact

**Fully automatic operation:** intake valve regulated by safety vacuum switch, coolant temperature control, thermostat and auxiliary control switches

**Coolant separator and recovery** for clean air exhaust without treatment

**Control panel** complete with main power switch, easy to operate

Model		UV4	UV8	UV16	UV24	UV30	UV50	UV100
Nominal Capacity at 50 Hz	m <sup>3</sup> /h	250	462	971	1.324	1.775	2.700	5.400
Operating Pressure range <sup>(1)</sup>	mbar(a)	450 - 0,5						
Water vapor Capacity <sup>(2)</sup>	kg/h	17	32	66	96	126	181	362
Pump Motor (400V)	kW	5,5	11	22	30	45	75	150
Rotation Speed	rpm	1.450	1.460	1.460	1.460	1.470	1.475	1.475
Fan Motor	kW	0,07	0,1	0,37	0,55	0,75	1	2x 0,75
Intake and Exhaust connections		2 ½" BSP	4" BSP	DN 125	DN 150	DN 150	DN 200 DN 150	DN 300 2x DN 150
Lenght	mm	825	1.600	1.385	1.600	2.270	2.670	4.180
Width		915	680	1.280	1.770	1.450	1.500	2.130
Height		1.170	1.775	2.180	2.180	2.050	2.250	2.100
Weight	kg	290	670	1.100	1.340	1.970	2.910	5.500
Total absorbed Power at 150 mbar(a)	kW	5,2	9	18	26	35	54	108
"VS" version Nominal Capacity variable speed, 4 poles motor, 35-60 Hz	m <sup>3</sup> /h	175 - 300	324 - 554	680 - 1.165	926 - 1.583	1.242 - 2.130	1.890 - 3.240	1.890 - 6.480

Performance according to ISO 1607 and DIN 28426

(1) from UV4 to UV100: 1013 - 0,5 mbar(a) upon request

(2) "H" version, Water Vapor Tolerance: 120 mbar(a)



UNI EN ISO 9001 and  
UNI EN ISO 14001  
certified



**Pneumofore**

Via N. Bruno, 34 - 10098 Rivoli (TO) ITALY  
Tel. +39 011.950.40.30 - Fax +39 011.950.40.40  
info@pneumofore.com - www.pneumofore.com

**SINCE  
1923**

SWISS ENGINEERING  
ITALIAN DESIGN  
GLOBAL PRESENCE

UV general metric, 50 Hz - May '18

Trademark and logo Pneumofore® are registered worldwide. It is strictly forbidden to make unauthorised copies of this document.  
No dissemination without written permission. © Pneumofore S.p.A. - all rights reserved.  
Printed on Tatami (Fedrigoni FSC certified paper) by Moglia, Torino